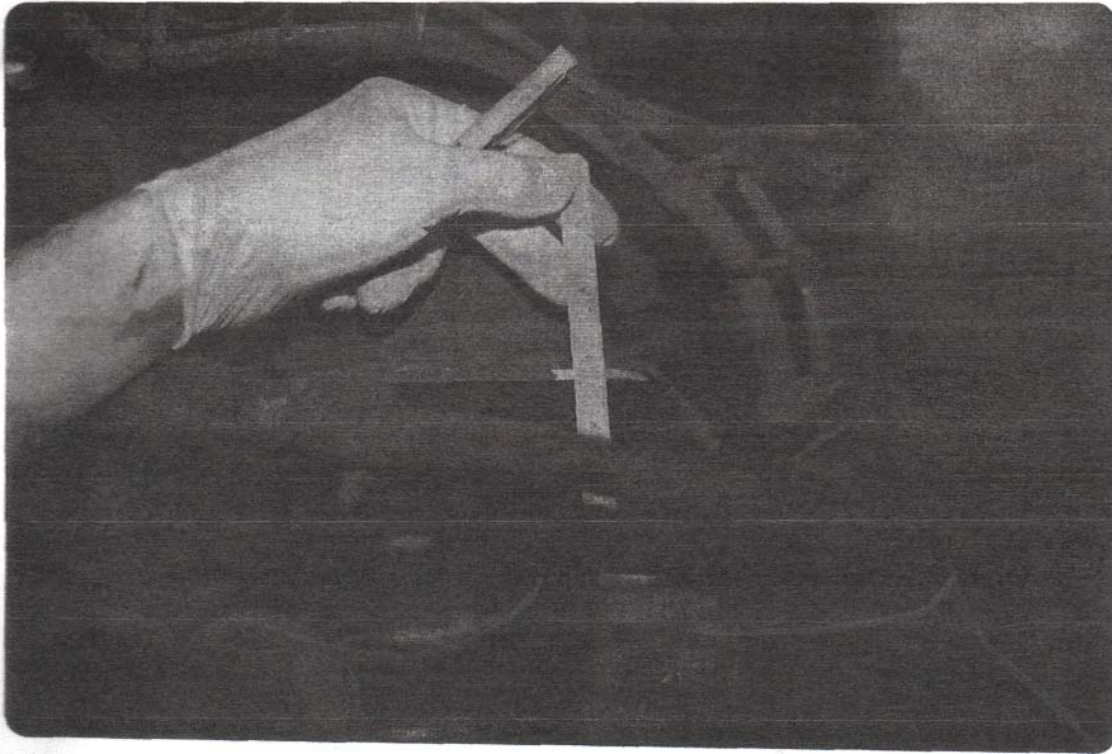

Fig. 12



Pictured:
P32 Chevrolet /
Workhorse
Class A Motor
Home

Check front suspension ride height.

Fig. 13

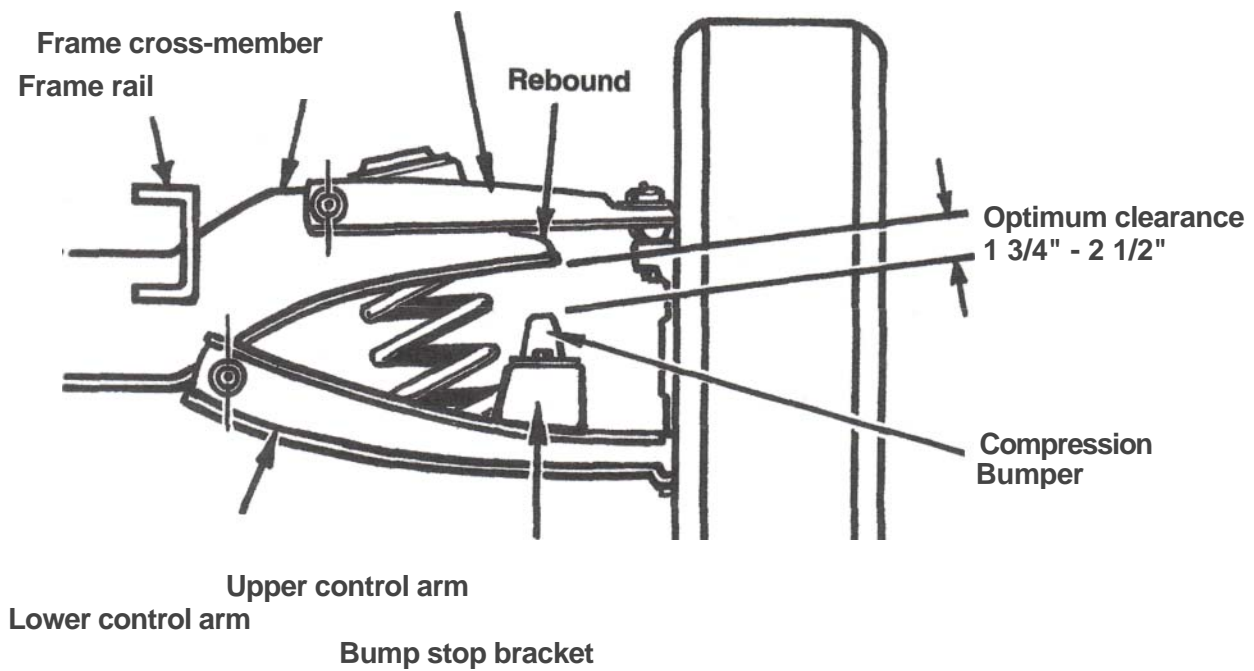

Measure at top of rubber bumper to the stop, measurement should be -
 $1\text{-}\frac{3}{4}'' - 2\text{-}\frac{1}{2}''$ ($2'' - 2\frac{1}{2}''$ optimal).